

CST STUDIO SUITE EMC FOR ELECTRONICS

Datasheet

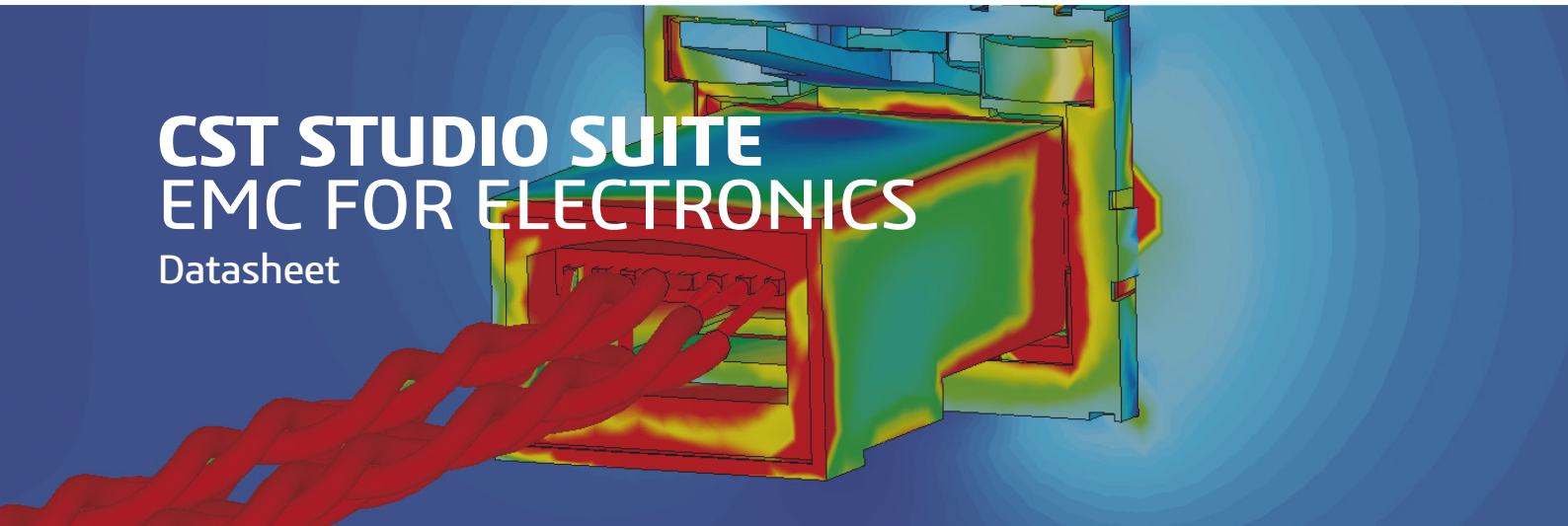

Electromagnetic compatibility (EMC) is an integral part of the development of any electronic device. By law, products must comply with international EMC standards which regulate EM emissions and the susceptibility of electrical and electronic systems in order to be sold. A successful product must strike a balance between EMC and competing design requirements such as size, cost and performance, and this can pose major challenges to engineers. The earlier a potential EMC problem is identified, the less disruption it causes to the design process. By including EMC compliant design at an early stage, additional costly development iterations can be avoided later on. Simulation using CST Studio Suite® allows problems to be identified and corrected from the start of the design process before the first prototype is even built. The software includes a range of solvers, ranging from PCB design rule checkers to fullwave 3D solvers to specialized cable and PCB solvers, which can be linked and hybridized with the CST Studio Suite System Assembly and Modeling (SAM) framework.

EMISSIONS

Parasitic coupling creates currents and fields in unintended regions. Wires, traces, seams and metallic components such as heatsinks can all behave like antennas, giving rise to radiated emissions, while cables and printed circuit boards can carry conducted emissions from one part of the system to another. Because of the risk that emissions pose to other devices, EMC regulations impose strict limits on the emissions that a device is allowed to produce.

Because shielding increases the cost, weight and form factor of a product, considerable savings can be made by reducing emissions at their source. Design rule checking with CST Rule Check solver can quickly analyze PCBs for potential EMC and SI/PI issues, highlighting areas where they might arise. Once potential problems have been identified, the design can be simulated using specialized SI and PI solvers as well as the the CST Studio Suite 3D full-wave solvers in order to perform a more thorough analysis.

The 3D full-wave simulator can accurately calculate radiated EM fields from the device, which are often a problem in highspeed electronics, as well as couplings on the device that can lead to conducted emissions problems. Low frequency EMC from power electronics can also be analyzed using the circuit simulator that is an integral part of CST Studio Suite.

SUSCEPTIBILITY

On the opposite side, the susceptibility or immunity of a device is a measure of how prone it is to external interference. As well as establishing emissions limits, many EMC regulations also specify the maximum allowed susceptibility of electronic devices. Products have to operate safely in their environment, and therefore must be immune from external influences like irradiation or conducted coupling which can affect the performance of a device under test (DUT) or cause it to fail. The effect of such an event on the DUT is difficult to trace through testing and measurements, and the coupling paths are often unclear. A CST Studio Suite simulation can visualize fields and currents – for example, from an ESD or BCI event – inside the device, allowing the engineer to identify critical areas and unforeseen coupling paths in order to apply countermeasures.

SYSTEM SIMULATION

Sometimes, one part of a system interferes with another. Full system simulation and hybrid simulation can be used to model the propagation of fields right through a system in order to characterize effects such as inter-system coupling and RF interference.

For these applications, CST Studio Suite offers the ability to link solvers together in order to hybridize the simulation. In addition to the hybrid cable solver, CST Studio Suite also allows circuit and fullwave 3D simulation to be linked using true transient EM/circuit co-simulation, allowing nonlinear components such as IBIS, SPICE or Touchstone files to be included in a 3D model.

GRAPHICAL USER INTERFACE

All CST Studio Suite solvers are integrated in one user interface, allowing users to perform comprehensive simulation workflows in a single software package.

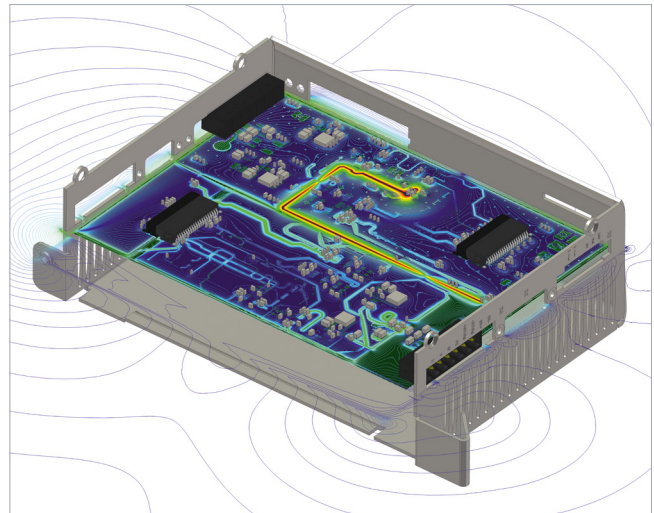

Radiated emissions: Fields from a PCB in an enclosure.

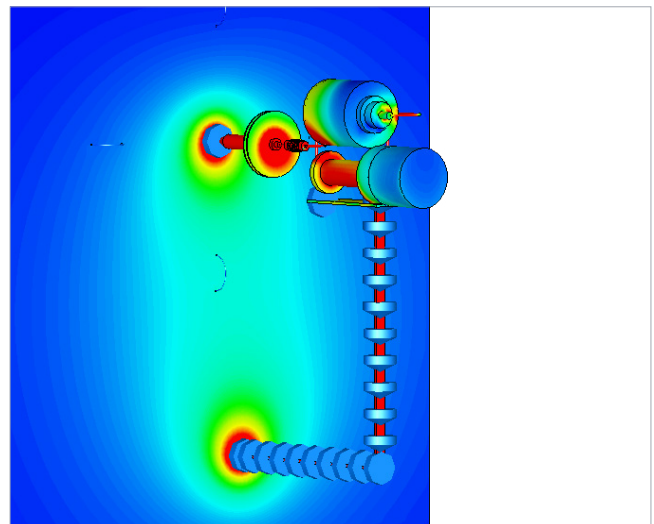

Electrostatic discharge: Surface current distribution of a highly-detailed model of an ESD generator.

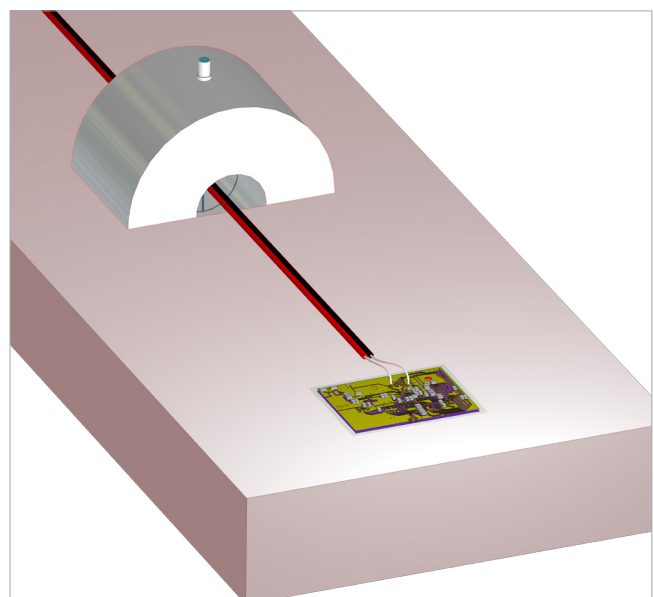

Bulk-current injection: Simulation of a BCI test of a PCB.

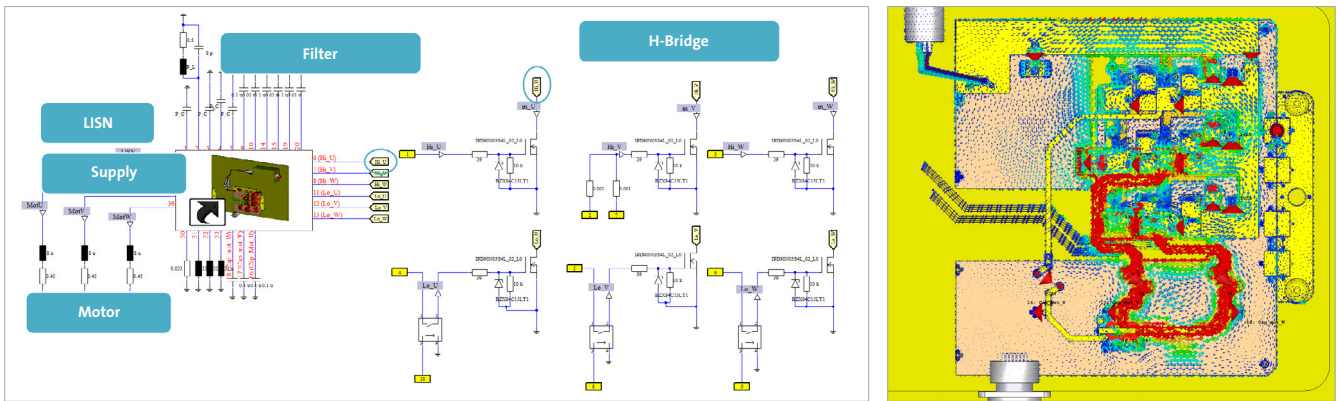

Conducted emissions: A variable frequency drive (VFD) motor control, showing the circuit level representation (left) and 3D surface currents (right).

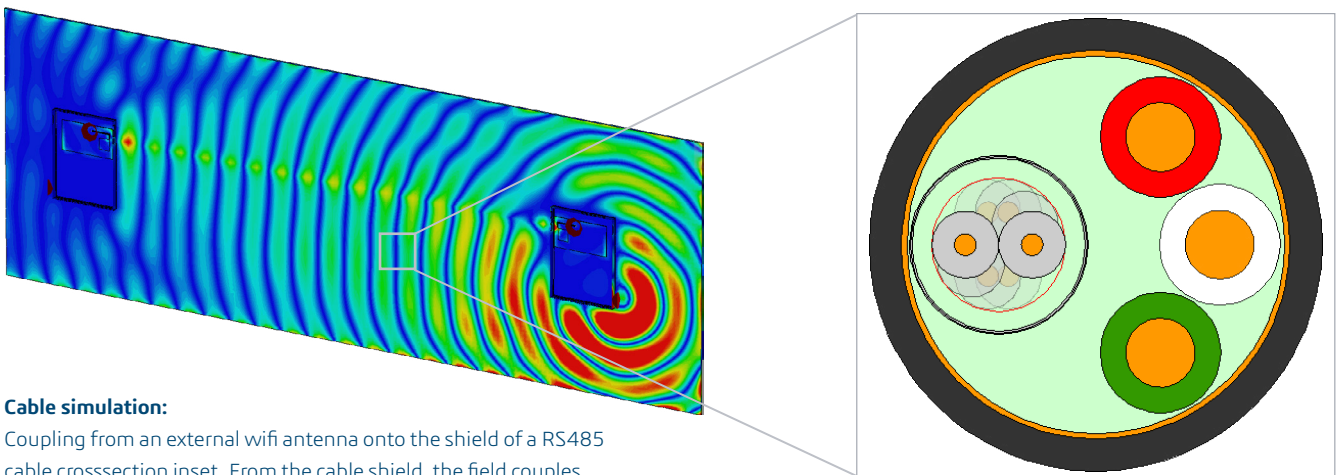

Cable simulation: Coupling from an external wifi antenna onto the shield of a RS485 cable crosssection inset. From the cable shield, the field couples through a connector to the inner PCBs.

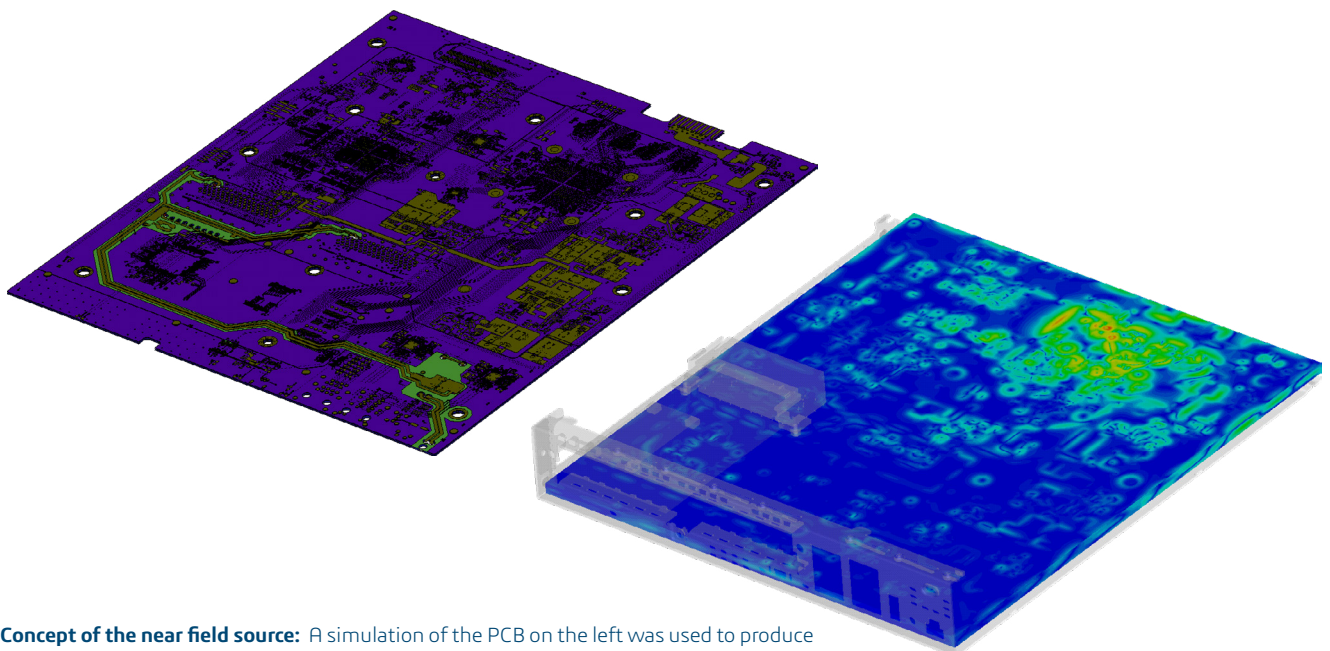

Concept of the near field source: A simulation of the PCB on the left was used to produce the field source on the right, which can then be used as a source in a simulation of an enclosure.

3D solvers can also be linked using nearfield sources to transfer calculated fields from one simulation to another, allowing the most efficient solver to be used for each part of the problem. The ability to import nearfield sources also allows measured data – for example, the measured nearfield from a component – to be imported and used as the basis of a simulation. The CST Studio Suite System Assembly and Modeling framework can be used to create and manage linked simulations.

CABLES

Cables are a common coupling route for fields into and out of otherwise well-shielded enclosures. One typical susceptibility concern is the coupling of EM energy through cables connected to the device. EMC countermeasures in cables often included twisted-pair wires and shielding, both of which give cables a intricate structure. Such complex cables and cable harnesses can be easily analyzed using the CST Studio Suite cable solver. The sophisticated hybrid bi-directional coupling of the cable solver to 3D full-wave solvers allows fast and accurate calculations and makes modeling complex cables in a 3D environment simpler and more intuitive.

DESIGN RULE CHECKING

The EMC performance of a printed circuit board is mostly based on the placement of components and nets. Manually checking all the layers of today's high speed circuit boards is too time-consuming and prone to human error. The CST Studio Suite Rule Check solver reduces the human error involved in the rule checking processes. CST Boardcheck rigorously analyzes complete PCBs against a list of selected EMC, SI and PI design rules. After the rule checking is completed, all EMC rule violations found in the design can be easily located.

Signal specification library

Design rules are dependent on the properties of the signal the net carries. CST Studio Suite Rule Check includes a signal specification library which automatically selects design rule parameters relevant to each net type based on the experience of EMC experts.

GENERAL FEATURES

- Import tools for 3D CAD and EDA formats
- Rule-based boardchecking with signal specification library
- Full-wave 3D solvers in the time and frequency domain
- Specialized cable simulation module supporting arbitrary cable complexity
- Coupling to circuit simulation in the time and frequency domain
- Support for IBIS, SPICE and Touchstone
- Outputs near and farfield, cylinder scan, S/Z/Y parameters, RLC extraction, voltages and currents in both time and frequency domain
- High performance computing options (hardware acceleration, MPI cluster computing, cloud computing)

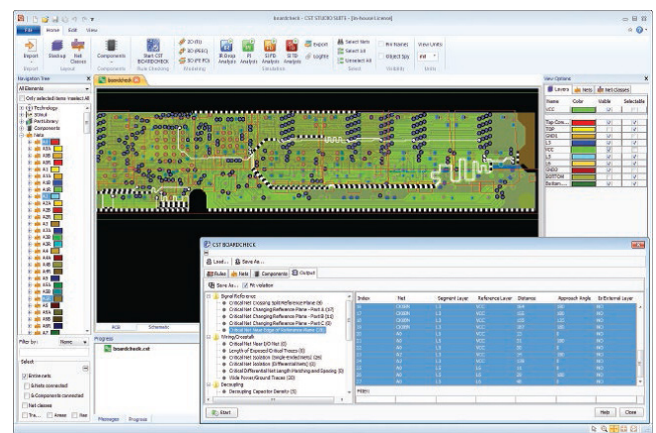

Rule checking: A violation reported by CST Studio Suite Rule Check.

Our 3DEXPERIENCE® platform powers our brand applications, serving 12 industries, and provides a rich portfolio of industry solution experiences.

Dassault Systèmes, the 3DEXPERIENCE® Company, provides business and people with virtual universes to imagine sustainable innovations. Its world-leading solutions transform the way products are designed, produced, and supported. Dassault Systèmes' collaborative solutions foster social innovation, expanding possibilities for the virtual world to improve the real world. The group brings value to over 210,000 customers of all sizes in all industries in more than 140 countries. For more information, visit www.3ds.com.

